



Perfect interaction between hydrostatic transmission, engine and hydraulics: the performance of the truck can be modified to match the requirements of the operator. Automatic engine acceleration on lifting is standard.



The pedals are mounted on the dashboard for easy maintenance.



The new full cab, available as an optional, is installed inside the profile of the overhead guard. It is equipped, in the standard version, with high-quality panelling, accessories and soundproofing, lexan roof complete with gutters, sliding windows and pantograph windscreen-wiper for more effective cleaning.



The hydraulic power steering unit is installed underneath the platform, giving simpler connections and quieter operation. The simple layout of components in the engine compartment facilitates rapid and efficient maintenance.

At Your Local Dealer

Options

- Balanced pedal direction control.
- Complete cab, with or without heating.
- Working lights.
- Cyclon pre-filter for dusty environment.
- Catalytic exhaust.
- Twin wheels.

Cesab Ltd:

Unit 10, Regent Park, Booth Drive, Park Farm South, Wellingborough,
Northamptonshire, NN8 6GR
Tel. +44 1 933 670 460 - Fax +44 1 933 679 854
e-mail: sales@cesab.net

Cesab Carrelli Elevatori Spa

Via Persicetana Vecchia, 10 - 40132 Bologna (Italy)
Tel. +39 051 20 54 11 - Fax +39 051 72 80 07
website: www.cesab-forklifts.com - e-mail: cesab@cesab.it



Drago E 250 300 350

The CESAB DRAGO E 250 300 350 are powerful and reliable high performance counterbalance fork lift trucks, featuring electronic hydrostatic transmission available in diesel and LPG versions. The range comprises models with lifting capacity from 2500 to 3500 Kg and lifting height up to 6110 mm.

3.3 litre diesel or 2.2 litre LPG low emission engines are available. The LPG version is equipped with an engine specifically developed for lift truck applications.

The comfortable, ergonomic driving seat is easily accessible thanks to the large, clearly visible step.

Ergonomically designed controls. The rotating-switch controlled parking brake is within easy reach of the driver. The new steering column is inclined towards the operator and easily adjustable for increased driving comfort.

The position of the uprights, which are widely spaced, guarantees excellent visibility and at the same time gives a rigid structure even at great height. Equipped with sideshift as standard.

The front wheels – which are among the largest in this class of trucks – guarantee load stability, operator's comfort and easy manoeuvring on uneven ground. Manoeuvrability is enhanced by a compact steering axle fully protected against the type of accidental impact damage typically associated with outdoor usage.

Increased maintenance and inspection intervals have significant benefits in terms of costs and machine down-times. Minimal maintenance for the no-wear-oil-immersed brakes.

IC counterbalanced trucks, Diesel and LPG, from 2500 to 3500 Kg

Powerful and reliable

Electronically controlled hydrostatic transmission



VDI 2198

		CESAB		CESAB		CESAB	
Characteristics	1.1	Manufacturer		CESAB		CESAB	
	1.2	Model designation		DRAGO E 250		DRAGO E 300	
	1.3	Power unit: electric (battery), diesel, petrol, LPG		diesel / LPG		diesel / LPG	
	1.4	Operation: manual, pedestrian, stand-on, driver seated		driver seated		driver seated	
	1.5	Load capacity	Q (kg)	2500		3000	
	1.6	Load centre	c (mm)	500		500	
	1.8	Axle centre to fork face	x (mm)	460	(a)	465	(a)
	1.9	Wheel-base	y (mm)	1750		1750	
	1820						
Weights	2.1	Weight	kg	4000 / 3890		4580 / 4470	
	2.2	Axle load with load, front/rear	kg	5890-610 / 5830-560		6730-850 / 6670-800	
	2.3	Axle load without load, front/rear	kg	2010-1990 / 1950-1940		2050-2530 / 1990-2480	
2050-2890 / 1990-2840							
Wheels and chassis	3.1	Tyres: C=Cushion, SE=Superelastic, PN=Pneumatic, TW=Twin		SE - PN - SE.TW - PN.TW		SE - PN - SE.TW - PN.TW	
	3.2	Tyre size, front		7.00-12 - 7.00-12 - 7.00-12 - 7.00-12		27x10-12 - 27x10-12 - 7.00-12 - 7.00-12	
	3.3	Tyre size, rear		6.50-10 - 6.50-10 - NO - NO		6.50-10 - 6.50-10 - NO - NO	
	3.5	Wheels, number front/rear (x = driven)		2x - 4x / 2		2x - 4x / 2	
	3.6	Track width, front	b10 (mm)	1042 - 1042 / 1153 - 1205		1002 - 1038 / 1153 - 1205	
	3.7	Track width, rear	b11 (mm)	1000		1000	
	1000						
Dimensions	4.1	Mast tilt, forward/backward	α / β (degrees)	5° / 9°		5° / 10°	
	4.2	Height of mast, lowered	h1 (mm)	2252		2252	
	4.3	Free lift	h2 (mm)	100		100	
	4.4	Lift height	h3 (mm)	3160		3160	
	4.5	Height of mast, extended	h4 (mm)	3805		3833	
	4.7	Height of overhead guard	h6 (mm)	2200		2200	
	4.8	Height of driver's seat	h7 (mm)	1150		1150	
	4.12	Towing coupling height	h10 (mm)	450		450	
	4.19	Overall length	l1 (mm)	3568	(a)	3697	(a)
	4.20	Length to fork face	l2 (mm)	2568	(a)	2697	(a)
	4.21	Overall width	b1/b2 (mm)	1215 - 1250 / 1540 - 1642		1254 - 1313 / 1540 - 1642	
	4.22	Fork dimensions	s/e/l (mm)	40 x 120 x 1000		45 x 120 x 1000	
	4.23	Fork carriage to DIN 15173, class/form A, B		II A		III A	
	4.24	Width of fork carriage	b3 (mm)	1100		1100	
	4.31	Floor clearance, mast (with load)	m1 (mm)	152		152	
	4.32	Floor clearance, centre of wheel-base (with load)	m2 (mm)	170		170	
4.33	Aisle width with pallets 1000 x 1200 across forks	Ast (mm)	3911	(a)	4022	(a)	
4.34	Aisle width with pallets 800 x 1200 along forks	Ast (mm)	4110	(a)	4221	(a)	
4.35	Turning radius	Wa (mm)	2250		2356		
4.36	Minimum distance between the centres of rotation	b13 (mm)	677		677		
693							
Performance	5.1	Travel speed, with/without load	km/h	20 / 21		20 / 21	
	5.2	Lifting speed, with/without load	m/s	0.49 / 0.51		0.47 / 0.51	
	5.3	Lowering speed, with/without load	m/s	< 0.59		< 0.59	
	5.5	Tractive force, with/without load	N	17000 / 16100		17000 / 16400	
	5.7	Climbing ability, with/without load	%	25 / 31		21 / 28	
	5.9	Acceleration time, with/without load	s	-		-	
	5.10	Service brake: mechanical/hydraulic/electric/pneumatic		hydrostatic		hydrostatic	
hydrostatic							
Drive	7.1	Engine manufacturer/type		Kubota V3600 / Toyota 4Y		Kubota V3600 / Toyota 4Y	
	7.2	Engine performance	kW	44 / 37		44 / 37	
	7.3	Rated speed	min ⁻¹	2200 / 2400		2200 / 2400	
	7.4	Number of cylinders/displacement	cm ³	4-3620 / 4-2237		4-3620 / 4-2237	
	7.5	Fuel consumption VDI-cycle	l/h; kg/h	-		-	
-							
Others	8.1	Type of drive control		stepless hydrostatic		stepless hydrostatic	
	8.2	Working pressure for attachments	bar	180		180	
	8.3	Oil flow for attachments	l/min	-		-	
	8.4	Noise level at driver's ear	dB (A)	81 / 79		81 / 79	
	8.5	Towing coupling, design/type DIN		-		-	

(a) with sideshift = + 25 mm (b) SE

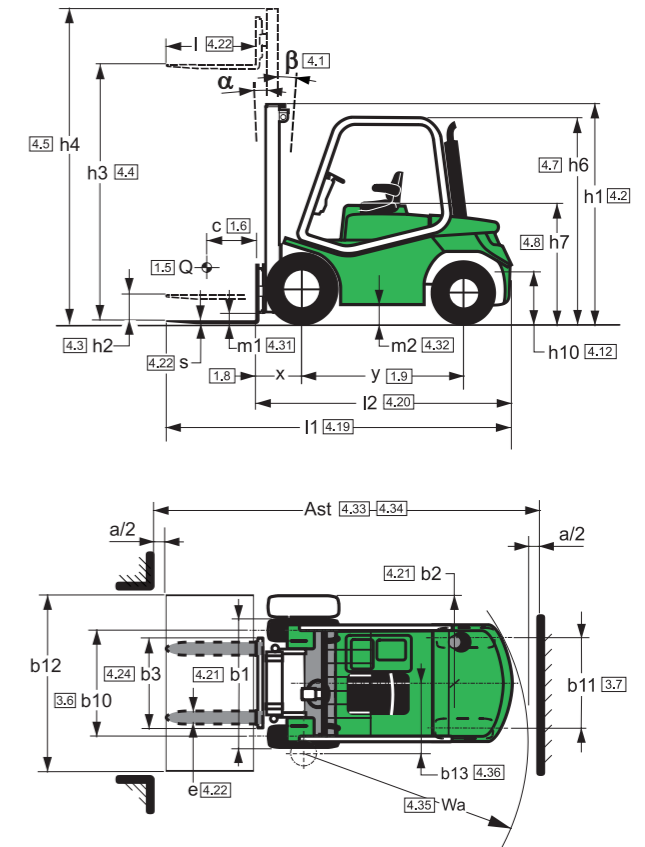

Masts specifications (2500 Kg)						
Mast	mm	Duplex				Duplex FFL
h3	Lift height	3160	3660	4160	4960	2930 3160
h1	Height of mast, lowered	2252	2502	2752	3202	2132 2252
h2	Free lift	100	100	100	100	1437 1557
h4	Height of mast, extended	3805	4305	4805	5632	3625 3855
α / β	Mast tilt forward/backward	5° / 9°				5° / 5°
Masts specifications (2500 Kg)						
Mast	mm	Triplex				Triplex FFL
h3	Lift height	4305	4965	5565	6765	4310 4460 4960 5560 6060
h1	Height of mast, lowered	2132	2352	2552	3052	2132 2182 2352 2552 2752
h2	Free lift	45	45	45	45	1437 1487 1657 1857 2057
h4	Height of mast, extended	4972	5632	6232	7532	5005 5155 5655 6255 6755
α / β	Mast tilt forward/backward	5° / 5°				5° / 7°
Masts specifications (3000 - 3500 Kg)						
Mast	mm	Duplex				Duplex FFL
h3	Lift height	3160	3660	4160	4960	2930 3160
h1	Height of mast, lowered	2252	2502	2752	3202	2132 2252
h2	Free lift	100	100	100	100	1436 1556
h4	Height of mast, extended	3833	4333	4833	5633	3626 3856
α / β	Mast tilt forward/backward	5° / 10°				5° / 6°
Masts specifications (3000 - 3500 Kg)						
Mast	mm	Triplex				Triplex FFL
h3	Lift height	4305	4965	5565	6765	4310 4460 4960 5560 6060
h1	Height of mast, lowered	2132	2352	2552	3052	2132 2182 2352 2552 2752
h2	Free lift	45	45	45	45	1436 1486 1656 1856 2056
h4	Height of mast, extended	4978	5638	6238	7532	5006 5156 5656 6256 6756
α / β	Mast tilt forward/backward	5° / 6°				5° / 8°

NOTES: Unless otherwise specified, all data refer to vehicles with SE tyres. All performance figures refer to fully run-in vehicles, in perfect working status with homologated tyres mix. Truck performance and dimensions are nominal and subject to tolerances.